

Janek Core Exchange Program

S, HT/S, DriveMaster®, and MSC3 Fan Drives

Janek Fan Drive Core Exchange Guidelines

1. The core must match one of the fan drives offered in the reman program. Full credit is issued if the sheave (pulley) and mounting bracket are not damaged. Partial credit is issued if either the sheave (pulley) or the mounting bracket is damaged. Zero credit if both the sheave (pulley) and mounting bracket are damaged.
2. The core must be complete to receive full credit. DriveMaster cores must contain a mounting bracket, a clutch pack, and a sheave. S and HT/S cores must include a mounting bracket, a sheave, a piston friction disc (PFD), and an air chamber. MSC3 cores must contain a mounting bracket, a sheave, a piston friction disc (PFD), an air chamber, a cooling ring, and an adaptor. The core is acceptable with or without fan mounting studs of any length and if the studs are bent or broken. A core will receive partial credit if any of the components are missing.
3. Main castings such as sheave (pulley) and mounting bracket must not be visibly cracked, broken, galled, or welded to receive full or partial credit.
4. If the sheave (pulley) or mounting bracket is damaged during shipment, the core will be considered for partial or zero credit as defined above. For this reason, the return packaging must protect the core from damage while shipping.

Full Credit	<ul style="list-style-type: none"> • A complete fan drive that is identical to the clutch purchased and the sheave (pulley) and mounting bracket are not damaged.
Partial Credit (Any one of Defect Codes C, D, E, F, G, H, or I)	<ul style="list-style-type: none"> • A complete fan drive that is identical to the clutch purchased, but has either the sheave (pulley) or mounting bracket damaged or • The fan drive is identical to the clutch purchased and is incomplete.
Zero Credit (Defect Codes A, B, or both C & D)	<ul style="list-style-type: none"> • The fan drive is not in the Janek Reman Program or • The fan drive is identified in the Janek Reman Program, but has both the sheave (pulley) and mounting bracket damaged or missing.

Defect Codes

- | | |
|---|------------------------------|
| A. A Competitors Drive | E. Core Missing PFD |
| B. Core not the same as purchased | F. Core Missing Air Chamber |
| C. Core Mounting Bracket Damaged or Missing | G. Core Missing Cooling Ring |
| D. Core Sheave Damaged or Missing | H. Core Missing Adapter |
| | I. Core Missing Clutch Pack |

Terms and Conditions of the Janek Reman Exchange Program:

When a remanufactured fan clutch is purchased, a core charge is debited to the Core Statement of Account. To avoid becoming due and payable, these charges must be offset within a specified time by the return and exchange of a qualified core.

- The terms of exchange are 30 days from the date of the core charge.
- Pricing is subject to change and is listed U.S. Funds
- A qualified core return will be credited to the Core Statement of Account and will offset the oldest outstanding core charge.
- **IF A CORE IS NOT RETURNED WITHIN 30 DAYS, THE CORE INVOICE BECOMES DUE AND PAYABLE WITHIN 30 DAYS.**
- Core returns will be accepted only for the purpose of offsetting core charges resulting from reman purchases.
- Credit balances (negative account balances) will not be refunded in cash. If not used within a one-year period, the credit will expire and be dropped from the Core Statement of Account.

Components and Parts

DriveMaster

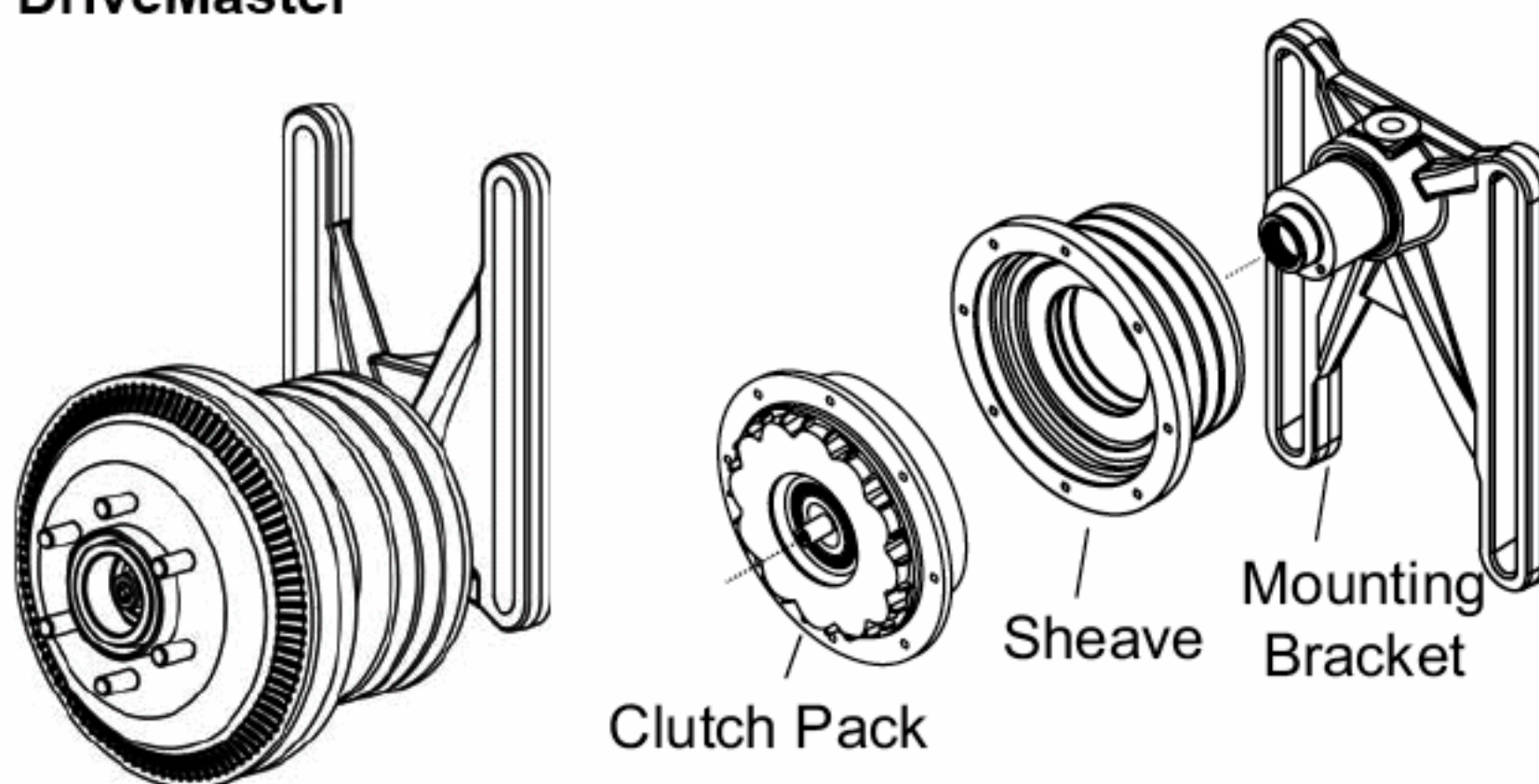

S & HT/S-Type Fan Drive

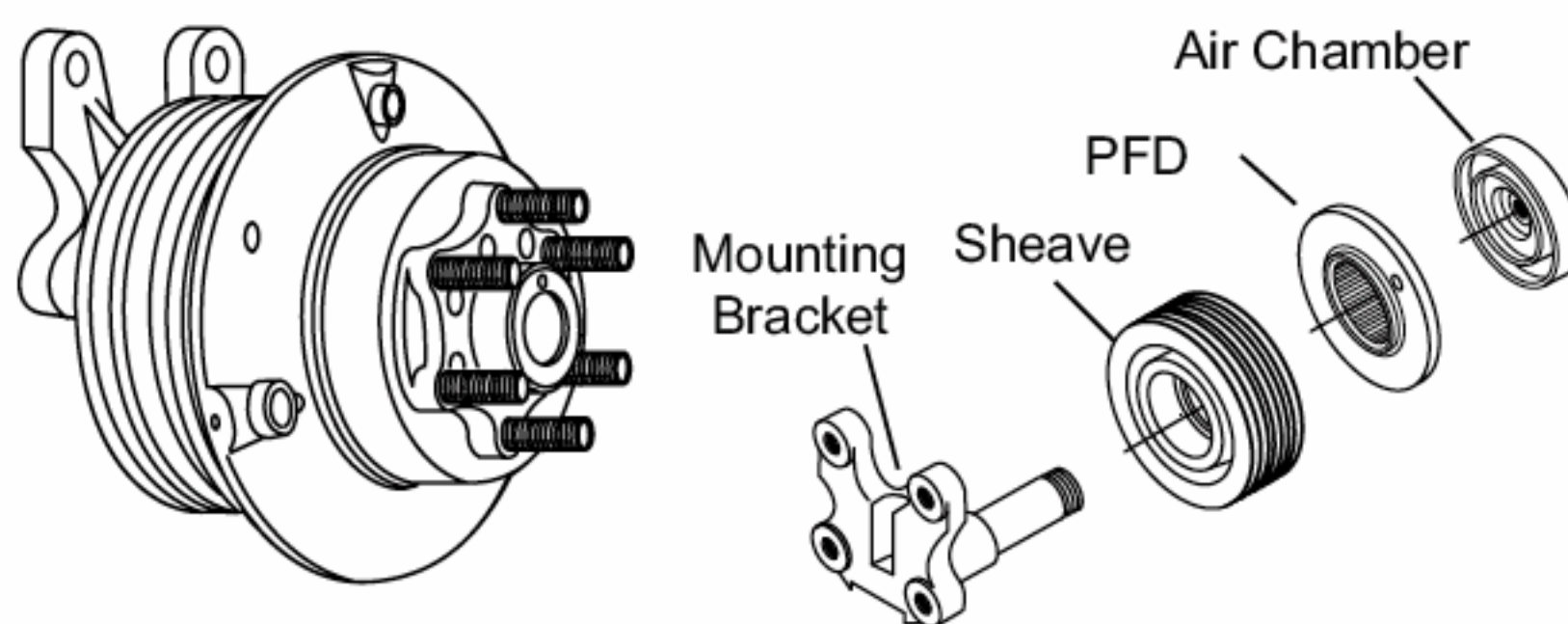

MSC3

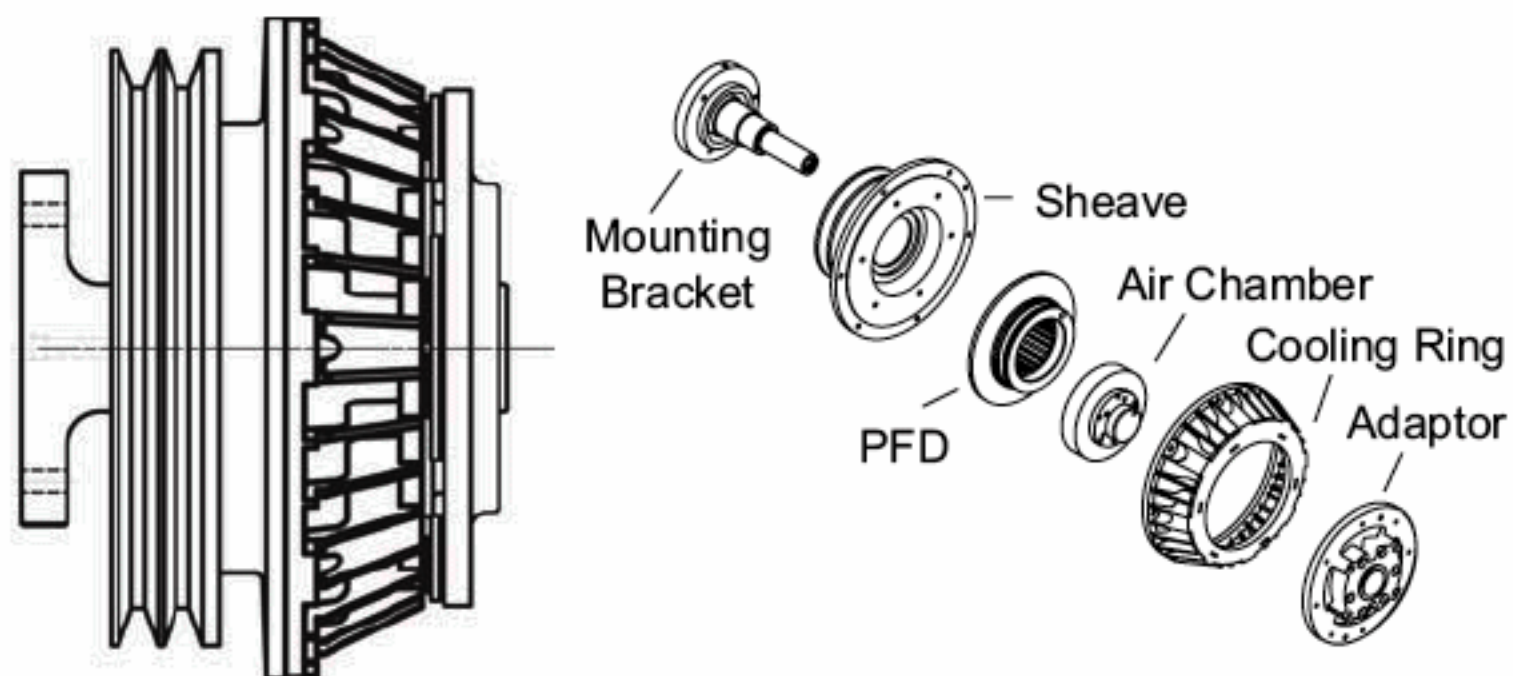

The Janek Corporation
655 Route 9 North
P.O. Box 904
Tuckerton, NJ 08087
609-294-1884 x10
Fax 609-294-2019
Web site: www.JanekCorp.com
e-mail: capgar@ejanek.com

